



PROJECT		REF		REV	ITEM CODE	
LOCATION		DATE			PAGE	

## SANITARY WARE SPECIFICATION SHEET

Item Descriptions	Stern (Israel) "Ever" Chrome plated deck mounted sensor faucet in 6x1.5AA DC Supply with <b>IP67 waterproof battery box</b>	Illustration/ Drawing 
Model	Ever Battery	
Code Number	230010	
Finish	Chrome Plated	
Supplier	Acme Sanitary Ware Co. Ltd Mr. Eric Wong/ Mr. Don Yuen	
Contact Tel/Fax E-mail Website	(852) 2388-7171 / (852) 2710-8012 acme@acmesanitary.com.hk www.acmesanitary.com.hk	

**EVER BATTERY Ref # 230010**  
 Touch-free electronic faucet for deck-mounted installations. Activated by infrared sensor. For hot or premixed water. Filters included. Chrome plated body, other finishes available. Battery version includes a low battery indicator. Adjustable setting by remote control : sensor range, security time, delay in, delay out, on-off and reset to factory setting. 24 hours mandatory hygiene flush available upon request.

**Application:**  
 Deck-mounted faucet. Combining an elegant minimalist design with anti-vandal features. Easy installation. Long lasting even in the harshest installation sites. Helps washrooms to stay clean and saves water. Prevents cross contamination. Ideal for stadiums, train and bus stations and highway rest stop.

**Use:**  
 Touch-free electronic faucet. The faucet is activated automatically when users place their hands n the sensor range and stops when the users remove their hands.

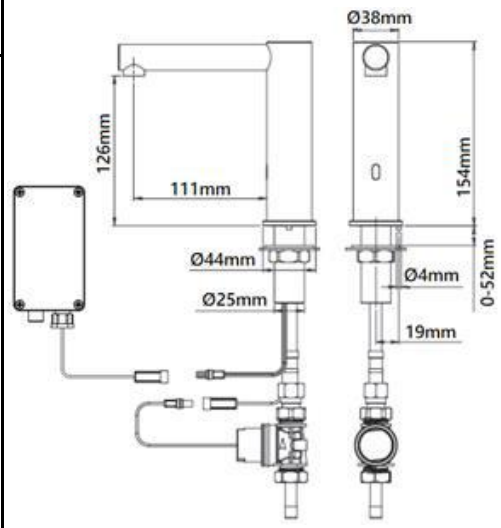

PRODUCT AT A GLANCE	
Installation	Deck-mounted
Power Supply	• 6X1.5V batteries • 9V transformer
Operating pressure	0.5-8.0 bAR / 7.0-116.0 PSI
Water supply	Cold or premixed water
Water Saving Options	5 LPM / 1.32 GPM ;1.89 LPM / 0.5 GPM
Water temperature	70°C Maximum
Security Time	Auto shutoff after 90 seconds. adjustable by remote control

-  **Installation:**  
Lavatory mounted
-  **Water supply:**  
Cold or premixed water (1 inlet)
-  **Water temperature:**  
Max 70 °C
-  **Operating pressure:**  
0.5 - 8.0 bar
-  **Power source:**  
IP67 battery box

ORDERING INFORMATION			OPTIONS	
MODEL	CODE	POWER	OPTION	CODE
EVER BATTERY	230010	6X1.5V batteries	Remote control	07100014
EVER MAINS	230000	9V transformer	Matching EVER SD BATTERY	230910
EVER BATTERY AISI316	230030	6X1.5V batteries	Matching EVER SD MAINS	230900
EVER MAINS AISI316	230020	9V transformer	Matching EVER SD BATTERY AISI316	230930
			Matching EVER SD MAINS AISI316	230920



\* All information of the above is for the reference only. No prior notice is made if any changes.

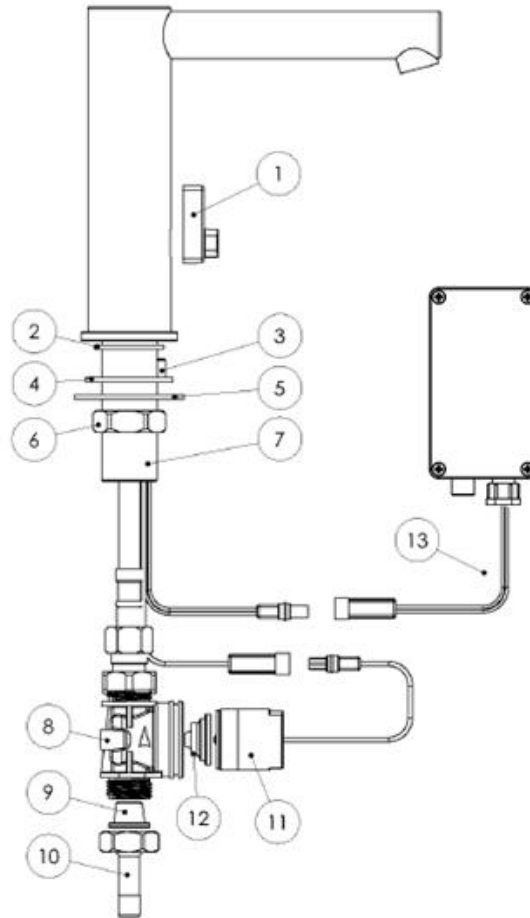

## SPARE PARTS LIST

**Ever Battery  
(230010)**

Quantity	Part Number	Description	Cat. No.
-	-	<b>Seals and Screws Kit</b>	<b>07210175</b>
1	2	O-ring	
1	4	Gasket	
1	3	Screw	
-	-	<b>10-Pack Sensor Kit</b>	<b>07220387</b>
-	-	<b>VR Brass SD Kit</b>	<b>07246036</b>
1	3	Screw	
1	7	Insert	
1	4	Gasket	
1	5	Disk	
1	6	Hexagon nut	
-	-	<b>8-Pack Solenoid BS-Housing Kit</b>	<b>07221119</b>
1	8	Solenoid valve's body	
1	9	Filter	
1	10	Nipple	
-	-	<b>10-Pack Solenoid Valve Kit</b>	<b>07232000</b>
1	11	Solenoid valve	
1	12	Diaphragm	
	<b>12</b>	<b>10-Pack Diaphragm</b>	<b>04500048</b>
	<b>13</b>	<b>IP 67 Battery Box</b>	<b>06530020</b>

**Note:** In order to locate the relevant spare part, please check the corresponding parts and part number in the drawing. Minimum order quantity will be required.

\* All information of the above is for the reference only. No prior notice is made if any changes.



## INSTALLATION

### STEP 1 – PREPARATION FOR MOUNTING THE FAUCET

**1** Shut off the water supply.



**2** Remove the hexagonal nut, the disk and the gasket. Do not remove the O-ring from the base of the faucet.

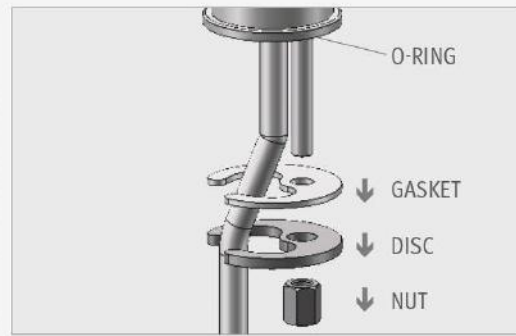

### STEP 2 – INSTALLING THE FAUCET

**1** Place the faucet with O-ring into the hole in deck or lavatory. Make sure the O-ring is located between the deck or lavatory and the bottom of the faucet.

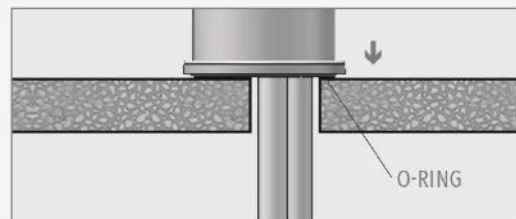

**2** Slide the gasket, disk and hexagonal nut over the flexible hose and secure the faucet into place.

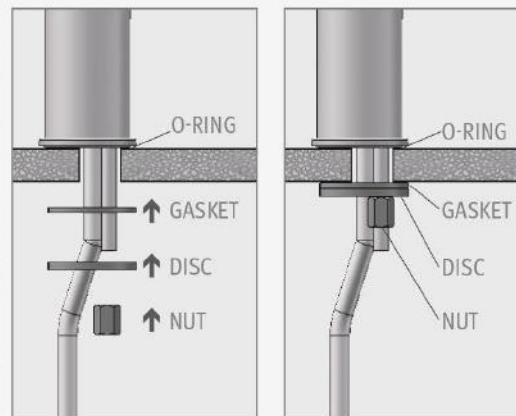



## INSTALLATION

### STEP 3 – CONNECTING THE WATER SUPPLY

1

Connect the flexible pipe to the water supply.

*For models with temperature control connect the red flexible pipe to the hot water supply and the blue flexible pipe to the cold water supply.*



**MAKE SURE THAT THE FILTER(S) IS/ARE INSTALLED BETWEEN THE FLEXIBLE PIPE AND THE SHUT OFF VALVE (ANGLE VALVE) (NOT SUPPLIED).**

2

Turn on the central water supply and the shut-off valves (angle valves) and check for leaks.

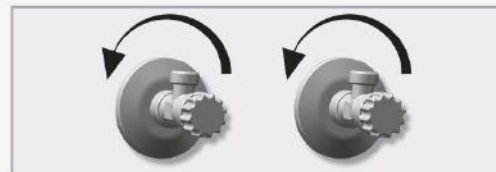



## INSTALLATION

### STEP 4 – CONNECTING THE POWER SOURCE

#### BATTERY VERSION

Install the battery box at the wall underneath the sink using the two sided adhesive foam tape. The cable connection must point down. (You can use an optional extension cable in order to assemble the battery box up to 10ft. away from the sink.)

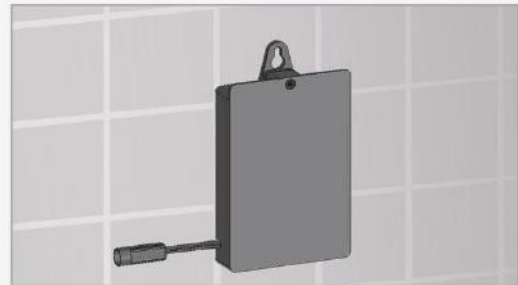

1

#### TRANSFORMER VERSION

Plug the transformer into the electricity socket and connect the connectors.



2

In order to avoid entering into the adjusting mode, wait 10 seconds before operating the faucet. If the range is unsatisfactory, refer to the section titled “settings adjustment.



ABOUT  
**10**  
SECONDS

NOTE: This model includes a special aerator that allows you to adjust the water stream direction on site in order to prevent water splashing if needed. To change the angle of the water stream, simply move the adjustable tilting plate by pressing it smoothly.

**ATTENTION! the aerator is tightened to prevent removal by hand.**





## TROUBLESHOOTING

PROBLEM	INDICATOR	CAUSE	SOLUTION
No water coming out of the faucet:	1. Sensor flashes continuously when user's hands are within the sensor's range.	Low battery.	Replace battery
	2. LED in the sensor does not flash once when user's hands are within the sensor's range.	1. Range is too short.	Increase the range
		2. Range is too long.	Decrease the range
		3. Battery is completely used up	The battery must be replaced.
	3. LED in the sensor flashes once when user's hands are within the sensor's range.	4. Unit is in "Security Mode"*	
5. Sensor is picking up reflections from the washbasin or another object.		Eliminate cause of reflection.	
1. Connectors between the electronic unit and solenoid are disconnected.			Connect the electronic unit connectors to the solenoid.
		2. Debris or scale in solenoid.	Unscrew solenoid, pull out the plunger and the spring from the solenoid and clean them. Use scale remover material if needed. When replacing the plunger, please make sure that the spring is in vertical position.
		3. The central orifice in the diaphragm is plugged or the diaphragm is torn	Clean the orifice or replace diaphragm.
	4. The water supply pressure is higher than 8 bar.	Reduce the supply water pressure.	
Water flow from spout does not stop:	5. The water supply pressure is under 8 bars and yet the pressure in the faucet's body is higher. This situation could be caused by a sudden increase in the water supply pressure that the back check prevents from dropping, even after water supply pressure drops under 8 bars.		Shut off water supply and unscrew one of the flexible pipes in order to reduce the pressure that blocks the product.
	1. Sensor flashes once when user's hands are within the sensor's range.	Debris or scale in diaphragm	Clean the orifice or replace diaphragm.
	2. LED in the sensor does not flash once when user's hands are within the sensor's range.	1. Sensor is dirty or covered.**	Clean or eliminate case of interference.
		2. Sensor is picking up reflections from the washbasin or another object.	Decrease the range or eliminate cause of reflection.
Water flow diminished		Filter or aerator is clogged	Remove, clean, re-install

\* "Security Mode": If the sensor is covered for more than 90 sec. the faucet will automatically shut off water flow. To return to normal operation remove any blockage.

\*\* In this case, the water flow will stop anyway after 90 seconds because of the security time.